

Installation Diagram

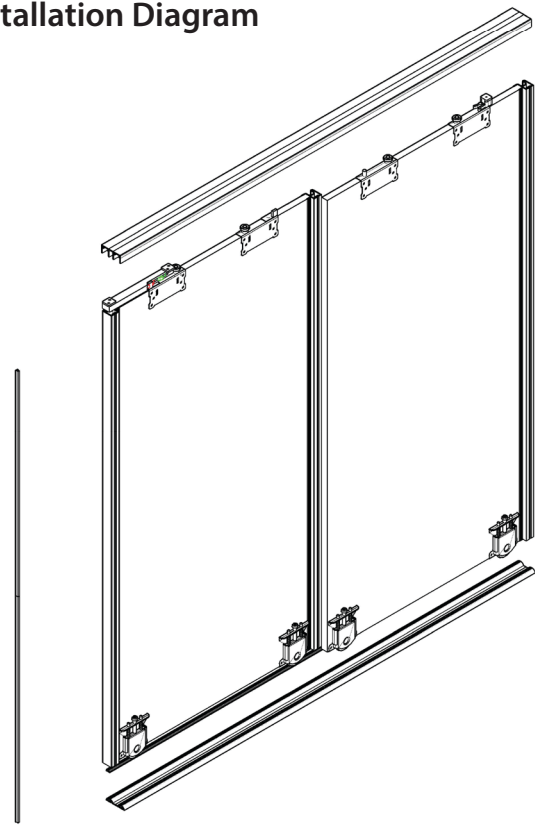

Installation

STEP 1

Cut the Profiles

Start by cutting the Top, Bottom and Pulling Profiles to the required lengths, as calculated previously.

STEP 2 - Soft Close Option

Insert Soft Close mechanism

Loosely screw the square plate, provided, to the Soft Close. Slide the square plate into the Top Profile, placing a Soft Close into each gutter. The Soft Close mechanism must face into the carcass, and away from the end of the Top Profile (see diagram). Tighten the square plate, to clamp the Soft Close mechanism in place.

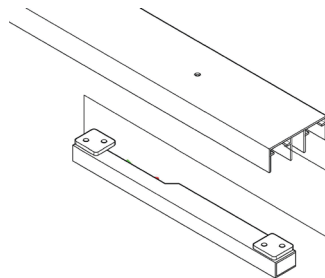

Repeat for all Soft Closes.

STEP 2 - Stop Catch Option

Insert Stop Catch

Slide the square caps into the Top Profile, placing a Stop Catch into each end of each gutter. The open end of each Stop Catch must point away from the end of the Top Profile (see diagram). Leave the Stop Catches loose in the Top Profile until the doors are installed.

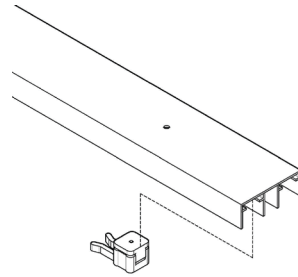

STEP 3

Install the Profiles

Secure the Pulling Profiles to both sides of the the doors panels.

Screw the Top Profile into the top of the carcass. Use Double Sided Hi Tac tape or screws to fix the Bottom Profile into the bottom of the carcass. The Bottom Profile must be recessed from the front edge of the Top Profile by 16mm.

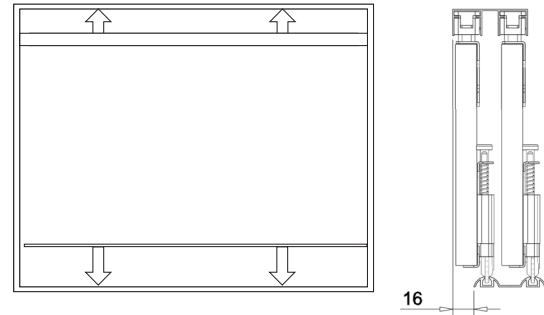
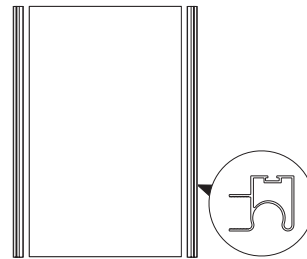

STEP 4

Mount the Rollers & Roller Guides

Attach the Bottom Rollers flush with the edge of each door panel.

Measure 125mm from the edge of the door to the edge of the Top Roller Guide. Screw the Top Roller Guides in place.

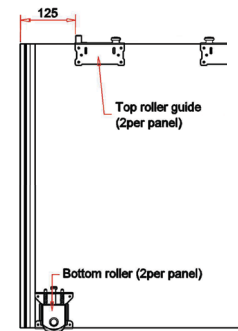

STEP 5

Install Doors

Place the doors into position by inserting the Top Roller Guides into the Top Profile, then place the Bottom Roller into the Bottom Profile.

Stop Catch: Once the door has been installed, slide the door into position. Slide the Stop Catch until it connects with the Top Roller Guide pin. Mark the Stop Catch position. Slide the door away and reposition the Stop Catch into the marked position, tighten the screw to clamp the Stop Catches in place.

Repeat for all Stop Catches.

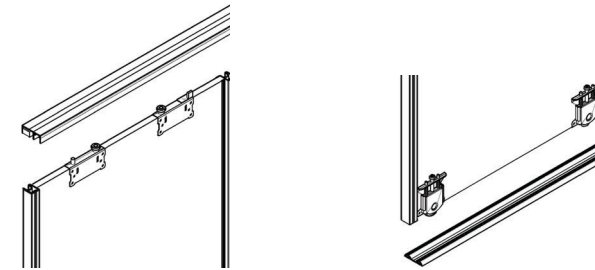

STEP 6

Adjust Bottom Rollers

To level the doors and for smooth operation, adjust the height of the Bottom Rollers. The maximum adjustment is 9mm. Be sure to tighten the lock nut once the adjustment is complete.

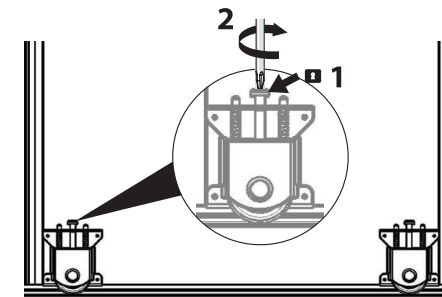

DIY Installation Guide

Sliding Door System

with Soft Close or Stop Catch

Gelmar

Sliding Door Fittings

Profiles

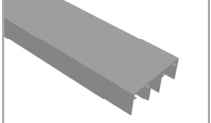

Top Profile

Code	L
9359	2m
9358	3m
9357	5m

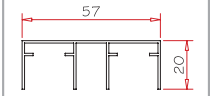

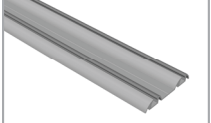

Bottom Profile

Code	L
9362	2m
9361	3m
9360	5m

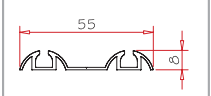

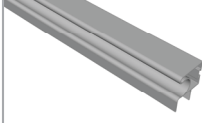

Pulling Profile

Code	L
9363	2.7m

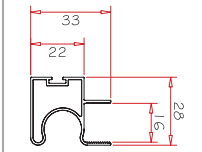



Preparing for Installation



max. 30kgs per door

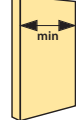

with Stop:
min. 750mm door width
with Soft Close:
min. 900mm door width

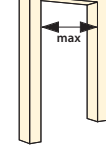

max. 5000mm Internal width

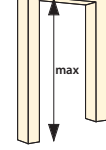

max. 2700mm Internal height

Door Measurement Guide

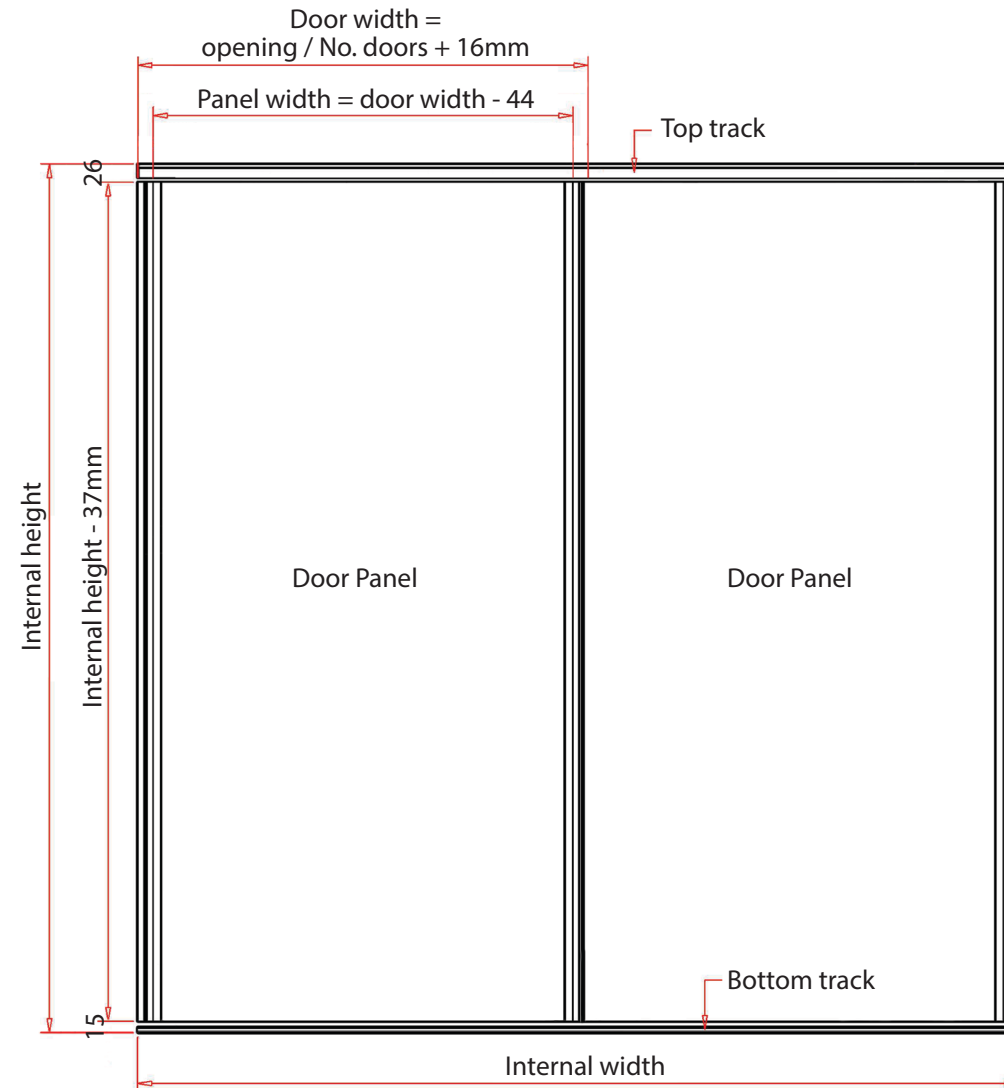

Single Door Kits

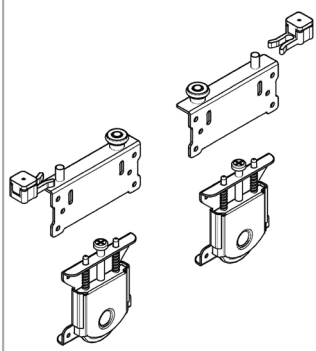

1 Door Component Set - with Stop (9366)

Upper Guide	Bottom Roller	Stop
2	2	2

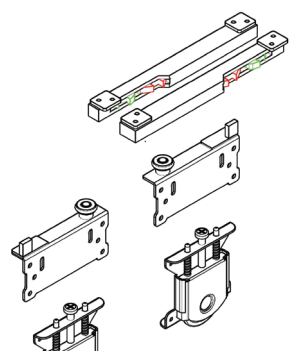

1 Door Component Set - with Soft Close (9365)

Upper Guide	Bottom Roller	Soft Close
2	2	2

Preparation - STEP 1

Measure the internal height and width of the cupboard.

Maximum internal width is 5000mm and maximum height is 2700mm.

Preparation - STEP 2

How many doors are required?

To calculate the size and number of doors required, use the following guidelines.

Door Width (with Pulling Profiles):

2 Equal Doors	3 Equal Doors
$= \text{Internal Width} \div 2 + 16\text{mm}$	$= \text{Internal Width} \div 3 + 16\text{mm}$

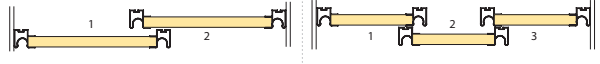

Door Height = Internal Height - 37mm

Top Guide Profile = Internal Width

Bottom Guide Profile = Internal Width

Example

Internal width = 2000mm
Internal height = 2200mm

Door Height: $2200 - 37 = 2163$

Door Width: $2000 \div 2 = 1000$

$1000 + 16 = 1016\text{mm}$

Panel Width: $1016 - 44 = 972\text{mm}$

Preparation - STEP 3

What must be purchased?

For each door system, the following is required:

- A Single Door Component Set *per door*
 - Either Single Door Component Set with stop
 - OR Single Door Component Set with soft close
- Top Guide Profile
- Bottom Guide Profile
- 2 x Pulling Profile *per door*

Note: You will need Pulling Profiles on both sides of the door.