

SWINGBINCH

RIGHT HAND

INSTALLATION

- 1 Cut out the hinge hole and cut along line **X**.
- 2 Align **X** on the template with bottom of cabinet and align **Y** with front edge of cabinet. Mark screw hole centres for brackets **A**, **B** and **C**.
- 3 Remove template and screw brackets **A** and **B** to inner cabinet and screw bracket **C** to door.
- 4 Fit hole on lower bin housing (**D**) onto bracket **A** and slot onto bracket **C**.
- 5 Push pin **E** through hole in bracket **B** into hole in upper bin housing (**D**).
- 6 Fit cover **F** to bracket **B** and insert bin **G** into bin housing **D**.

All dimensions in mm.

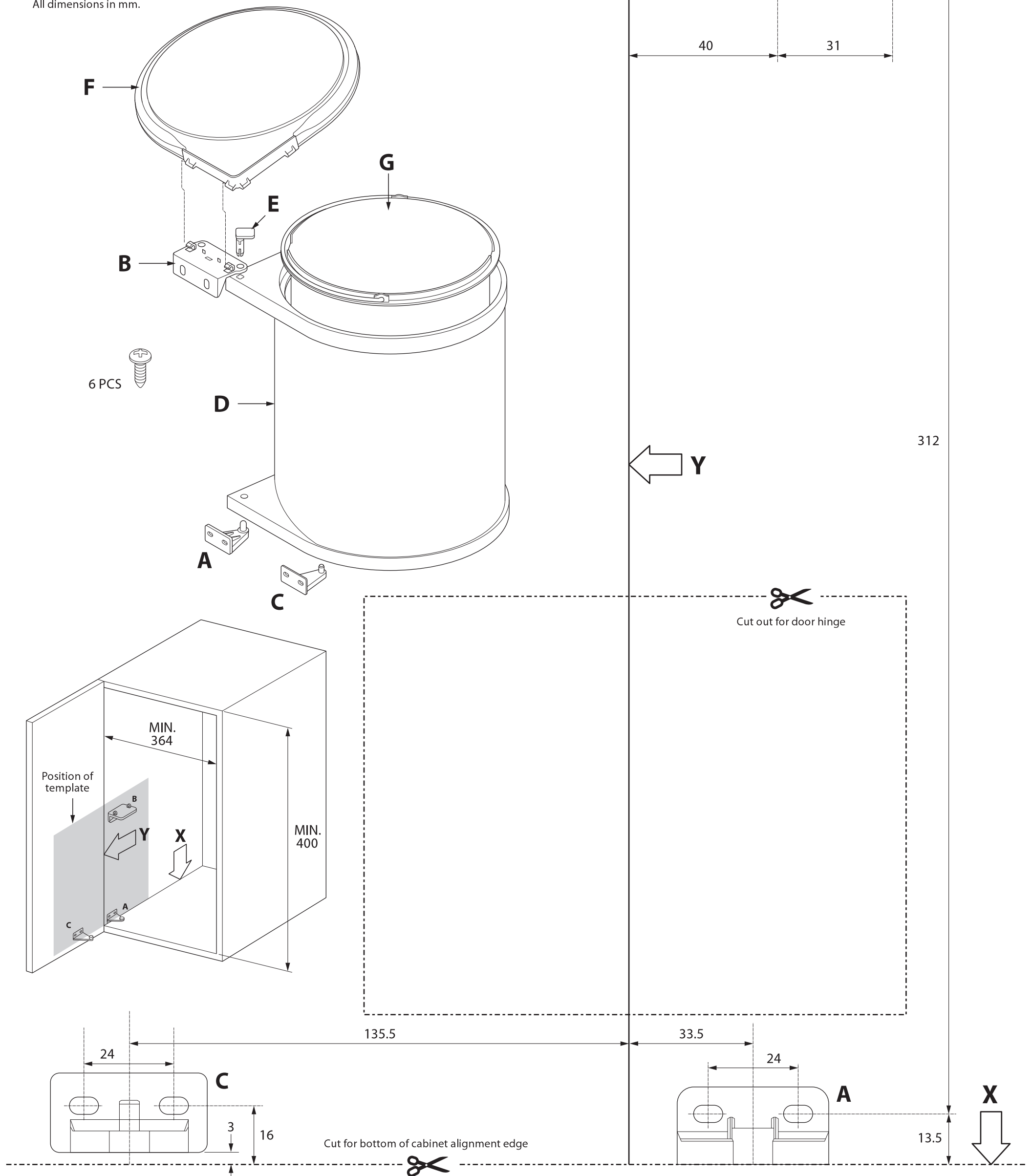

SWINGGBINCH RIGHT HAND

INSTALLATION

- 1 Cut out the hinge hole and cut along line **X**.
- 2 Align **X** on the template with bottom of cabinet and align **Y** with front edge of cabinet. Mark screw hole centres for brackets **A**, **B** and **C**.
- 3 Remove template and screw brackets **A** and **B** to inner cabinet and screw bracket **C** to door.
- 4 Fit hole on lower bin housing (**D**) onto bracket **A** and slot onto bracket **C**.
- 5 Push pin **E** through hole in bracket **B** into hole in upper bin housing (**D**).
- 6 Fit cover **F** to bracket **B** and insert bin **G** into bin housing **D**.

All dimensions in mm.

